

## Vertical Extension Pipe for AU4040 Bottle P Trap - Matte Black

**Code:** AU4040-VEMB

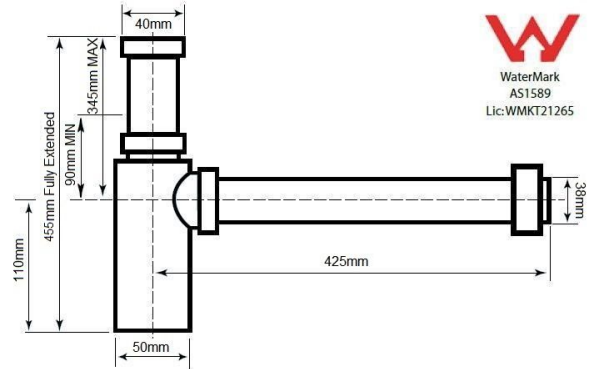

When Using the AU4040-VE Vertical Extension

### Specifications

- Finish: Matte Black
- 300mm long - increases bottle trap with code AU4040MB max vertical set out to 345mm
- Durable electroplated finish with anti-corrosion protective lacquer

### Warranty

For peace of mind, Turner Hastings offers the following warranty on this product and its components:

Pipe - 1 year

For more details, [click here](#) to refer to our warranty page.