

Code EA90STRS – 90cm Straight Touch Control Canopy



LCD DISPLAY CONTROL

The stunning blue LCD display provides the Rangehoods, stylish design. This feature displays extraction speeds plus the time of day.

3 SPEED MOTOR

This range hood provides the option of 3 different speed levels ensuring you have the option to use your range hood at a low, medium or high level of operation.

HIGH EXTRACTION CAPACITY

The extraction capacity of 1000m³/hr provides strength and power to this stylish range hood.

COMMERCIAL STYLE BAFFLE FILTERS

Easy clean, stainless steel baffle filters, are designed to capture all steam & moisture, whilst removing exhaust & odors from the kitchen. Perfect for use over fast heat up cooktops, like induction.

DECIBEL RATING

53-66 dBa

FEATURES

- Stainless steel + black glass finish
- 3 speed aluminum alloy motor
- 1000m³ / hr extraction capacity
- 2 x 0.5W LED lights
- Separate light function
- LCD display
- 3 piece commercial style baffle filters
- 150mm air flow outlet

TIPS FOR BETTER USE

- Leave your range hood on for 15 minutes after the cooking of the food to remove all odors, steam etc.
- The dishwasher-safe cassette filters need to be cleaned after approximately 2 months of standard operation
- It is recommended the range hood be installed between 650mm and 750mm above the cook top
- It is also recommended that fumes from the range hood be ducted out into the atmosphere.
- Turn off the range hood before attempting to clean
- **Installation recommended by qualified installer.**



LCD display



0.5W LED lights



Baffle filters

PRODUCT DIMENSIONS

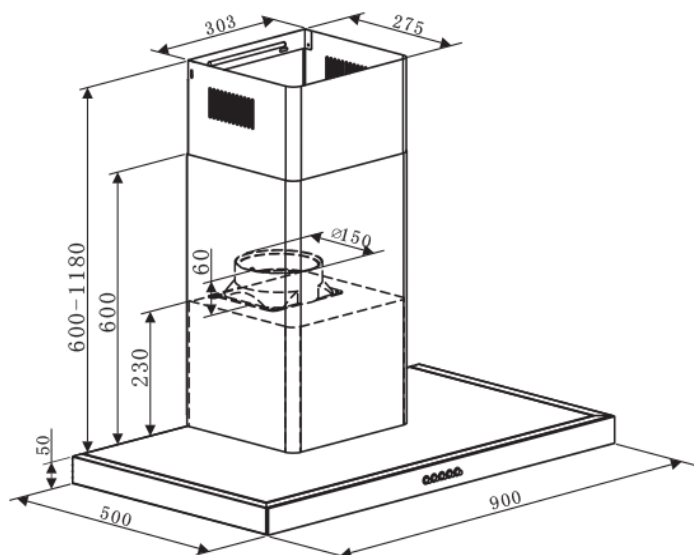

ELECTRICAL REQUIREMENT:

Range hood is supplied with 10amp cord & plug.

OPTIONAL ACCESSORIES

Carbon Filter Code: CF260 (requires x1)

RANGEHOOD EXTENSIONS

Flue Extension 1m Code: EPEXT

RANGEHOOD VENTILATION KITS

RHKE65 – Wall – Eave vent kit

RHKMR65 – Universal metal roof kit, includes flashing

RHKTR65 – Universal tile roof kit, includes flashing

BAFFLE FILTER CLEANING INFORMATION:

Baffle filter : requires cleaning monthly

This will ensure no interruptions with airflow operation.

