

30cm Ceran Touch Electric

COOKTOP

PRODUCT CODE: ECT32C



FEATURES:

- + Easy clean Ceran glass cooktop
- + 2 rapid elements, 9 heating levels
- + Front sensor touch control operation
- + Total Rated Load: 3.0kW
- + Residual heat indicator
- + Auto shutdown
- + 99 minute timer
- + Child lock function
- + Square edge design

2 RAPID ELEMENTS

To ensure rapid heat time this cooktop is fitted with 2 rapid elements.

SMOOTH CERAN GLASS COOKTOP

A high grade ceran glass is used for this cooktop to ensure easy cleaning of the smooth ceran surface.

SPECIFICATIONS:

Electrical Requirements	15Amp dedicated circuit from cooktop to main switchboard
Voltage:	220V - 240V
Frequency:	50Hz
Total rated load:	3.0Kw
Burner:	
Large Element	1800W (180mm Diameter)
Small Element	1200W (145mm Diameter)
Weight	9.0kg gross/ 8.0kg net
Product Dimensions	W288mm x D520mm
Barcode	9347726013473



eurocooking

3
YEARS

Warranty

INSTALLATION DIAGRAM

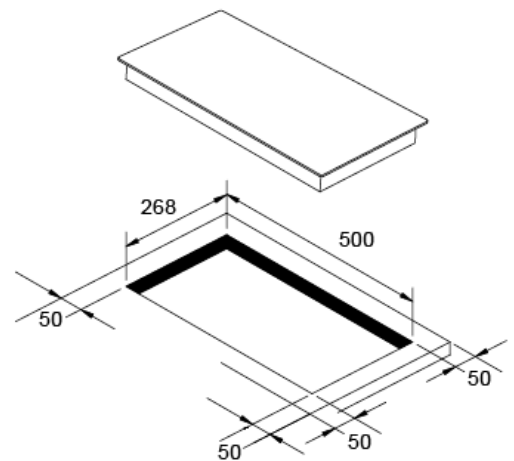

TIPS FOR BETTER USE

- + Always use pans with a flat base to ensure even contact with the hotplate
- + The correct size of pan should be used so that the whole of the hot plate is covered
- + Never switch on the hot plate without a pan in position as the hot plate can become distorted
- + To ensure even contact and to prolong the life of hotplates, the base of the pans should be kept clean and dry
- + Take care never to reach over the hot plate
- + Allow time to cool before attempting to clean