

BOSTON DOUBLE

Butlers Kitchen Sinks

860X462X255MM

SPECIFICATIONS

PRODUCT CODE MC84455

STYLE Reversible Basin with 2 different facings
Fluted Design Front and Pencil Line facing

DIMENSIONS 860X462X255mm

MATERIAL Ceramic

WATER CAPACITY 30L each bowl

Mounting Flush Mount, Top Mount, Undermount

Waste sold seperately WK105

PACKAGE INFO:

Package Size mm	Gross Weight kg
845 455 255	41

Package details Approximately only

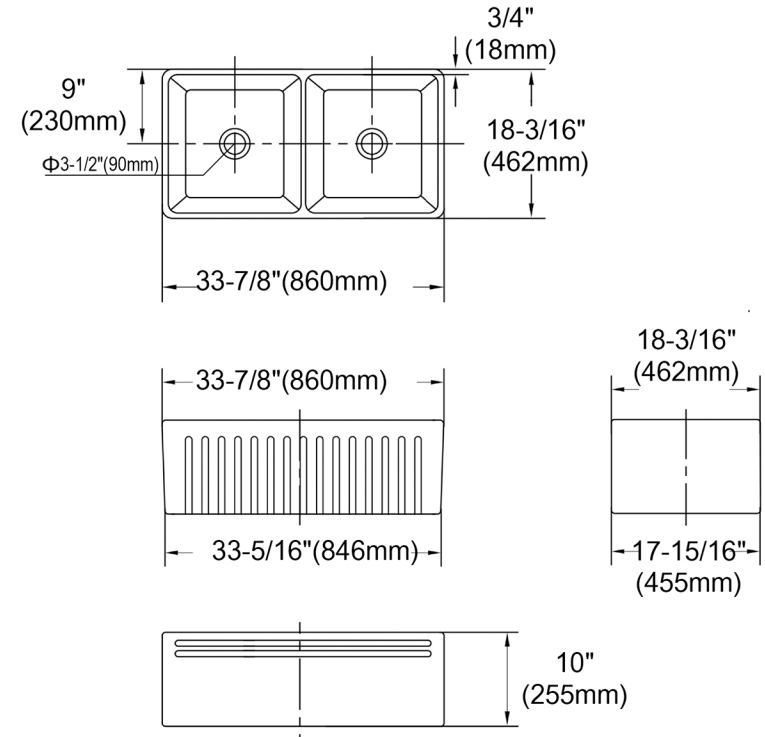

While we aim to ensure specifications are correct at the time of publication, OTTI reserves the right to make modifications without prior notice. Physical colour may vary from image shown.

All measurements are shown in millimetres. Always use physical product measurements for mark-ups and roughing-in as the technical drawing may differ from actual product received.

SPECIFICATIONS

Kitchen Sink must be installed by licensed plumber in accordance with local regulations and standards.

Note: Due to the nature of the material, dimensions should be used only as a guide, each sink can vary 1-2%. It is recommended that the sink is measured on site before cabinetry is built or stone is cut. Ensure your butler sink is provided to your cabinet maker and stone provider to allow them to cut to measure before making cabinetry or cutting stone.