

## KARA WALL TOP ASSEMBLIES

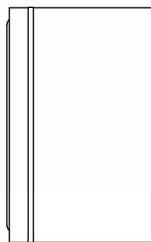
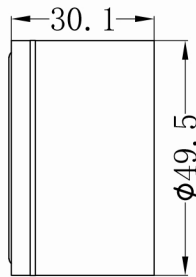

Dimensions are nominal measurements only.

## SPECIFICATION

PRODUCT CODE	YSW2117-09
WELS RATING	N/A
WATERMARK LICENSE	WM-060073
TEMPERATURE RATING	MIN 1°C-MAX 75°C
PRESSURE RATING	MIN 150KPa-MAX 500KPa

## FINISH

	NR211709CH	chrome
	NR211709MB	matt black
	NR211709BN	brushed nicke
	NR211709GM	gun metal
	NR211709BG	brushed gold

## MAINTENANCE AND CARE

All surfaces should be cleaned with mild liquid detergent or soap and water.

Do not use cream cleaners or citrus based cleaning products, as they are abrasive.

Use of unsuitable cleaning agents may damage the surface. Any damage caused in this way will not be covered by warranty

## PACKAGING INCLUDES

- 2x handwheel
- 2x valve
- 1x allen key
- 1x cartridge cutting metric block



1

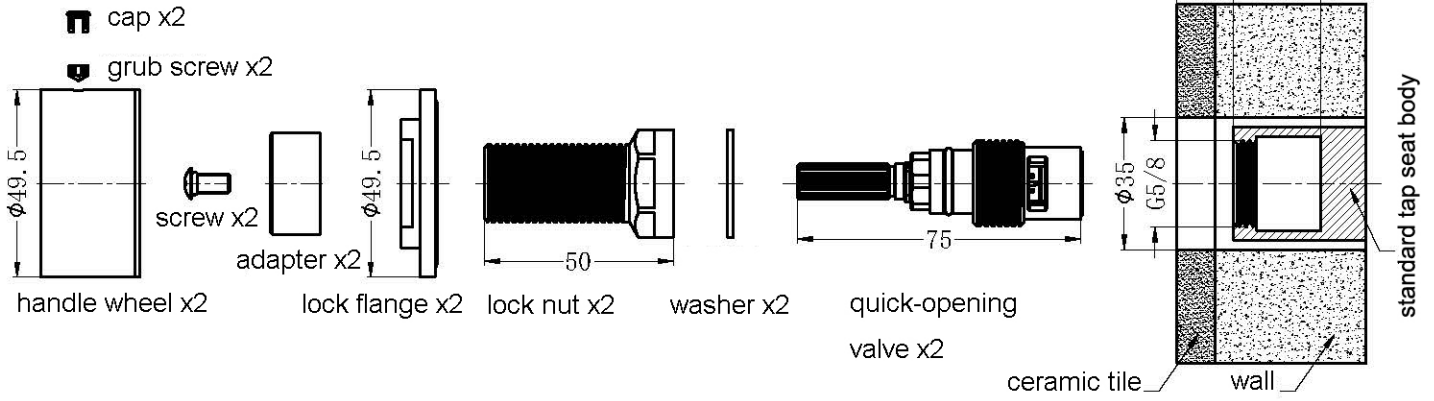

install standard tap seat body as the dimension.

2

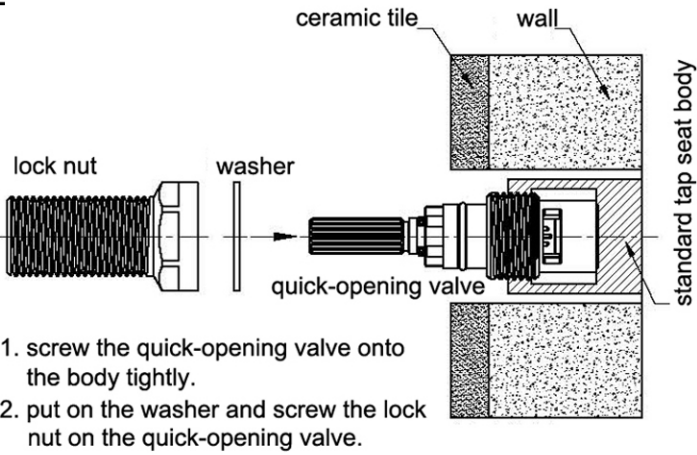

3

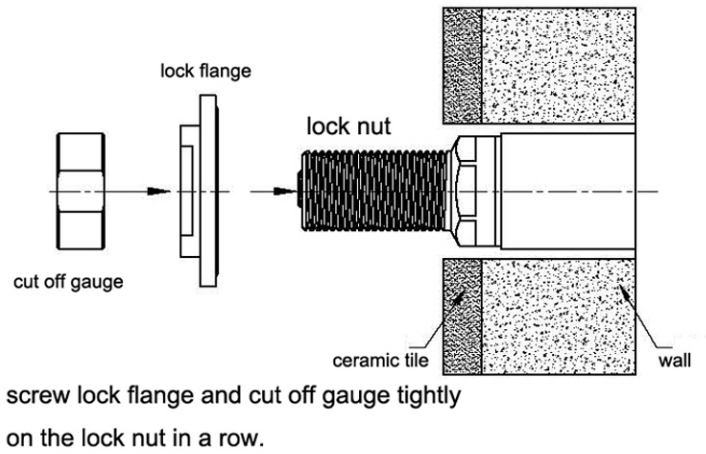

4

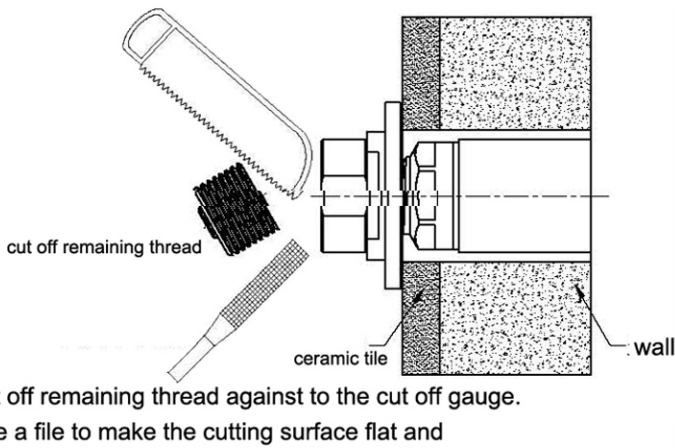

5

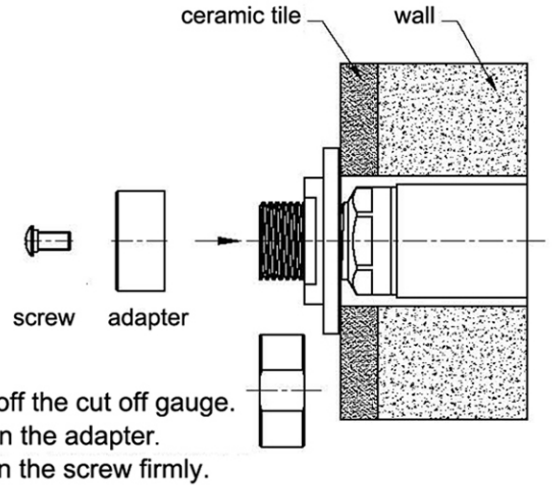

6

