

# R-SERIES: RECTANGLE SHAPE

PRODUCT CODE

RN9060

## LED MIRROR

### SPECIFICATIONS

WIDTH	900mm
HEIGHT	600mm
DEPTH	from 35-40mm
TOTAL WEIGHT	Less than or equal to 15kg

### AVAILABLE FEATURES

Copper Free Mirror
LED Lighting
Backlit
Portrait/Landscape

### OPTIONAL UPGRADES

Bluetooth
Demister
Adjustable Colour Temperature
Touch sensor

### LIGHTING SPECIFICATIONS

CRI	>80
<b>CCT OPTIONS</b>	
Warm White	2700K
Remer Standard	4000K
Cool White	6500K
	2700-6500K

### INSTALLATION

Wall mount
Input voltage: 220-240v 50Hz

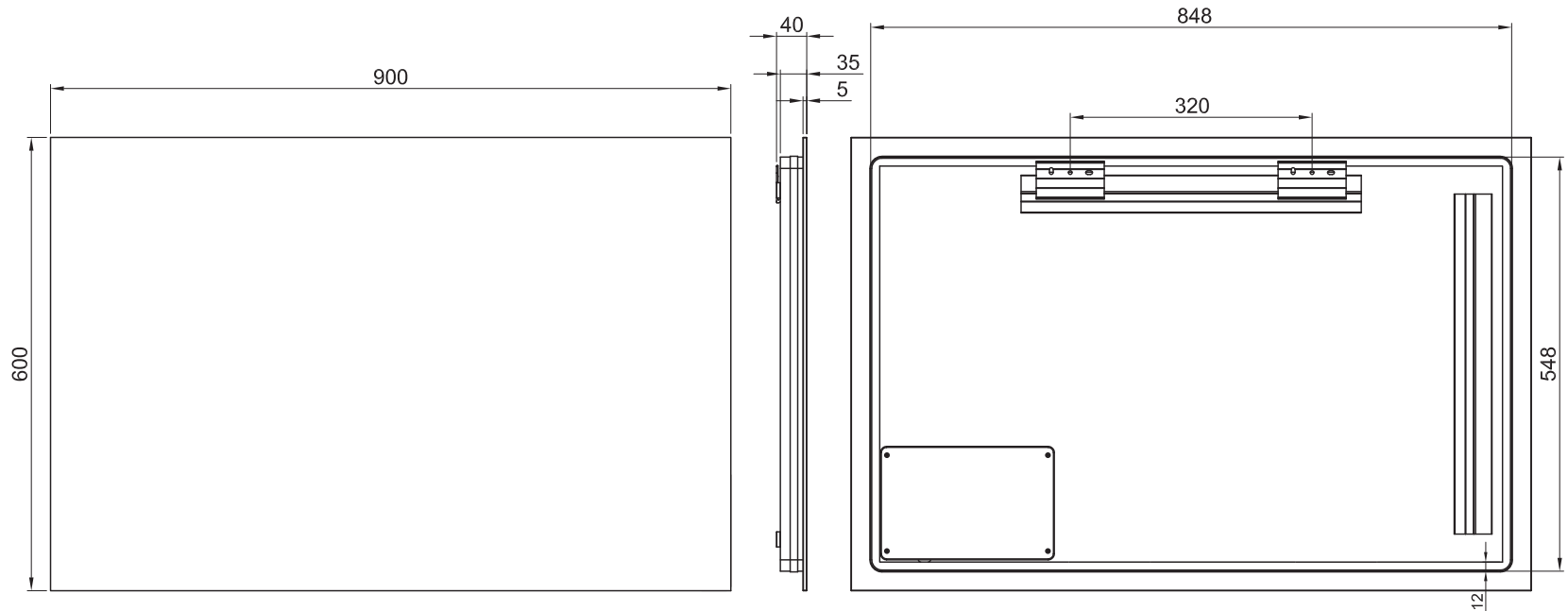

Sizes are in mm and nominal and should be checked prior to installation. Actual colours may vary so please check colour samples before ordering. Installation is acceptance of our products. Installation of faulty, warped, chipped or damaged products will void our warranty.

13-15 Edison Road, Dandenong South VIC 3175  
 T (03) 9706 6663 E sales@remer.com.au W remer.com.au



# R-SERIES: RECTANGLE SHAPE

## LED MIRROR WITH COLOURED ALUMINIUM FRAME

**PRODUCT CODE**

RN9060 – BB/BN/GM/MB/MW

**SPECIFICATIONS**

WIDTH	905mm
HEIGHT	605mm
DEPTH	from 38-43mm
TOTAL WEIGHT	Less than or equal to 15kg

**AVAILABLE FEATURES**

Copper Free Mirror  
LED Lighting  
Backlit  
Portrait/Landscape

**OPTIONAL UPGRADES**

Bluetooth  
Demister  
Adjustable Colour Temperature  
Touch sensor

**LIGHTING SPECIFICATIONS**

CRI >80

**CCT OPTIONS**

Warm White	2700K
Remer Standard	4000K
Cool White	6500K
	2700-6500K

**INSTALLATION**

Wall mount  
Input voltage: 220-240v 50Hz

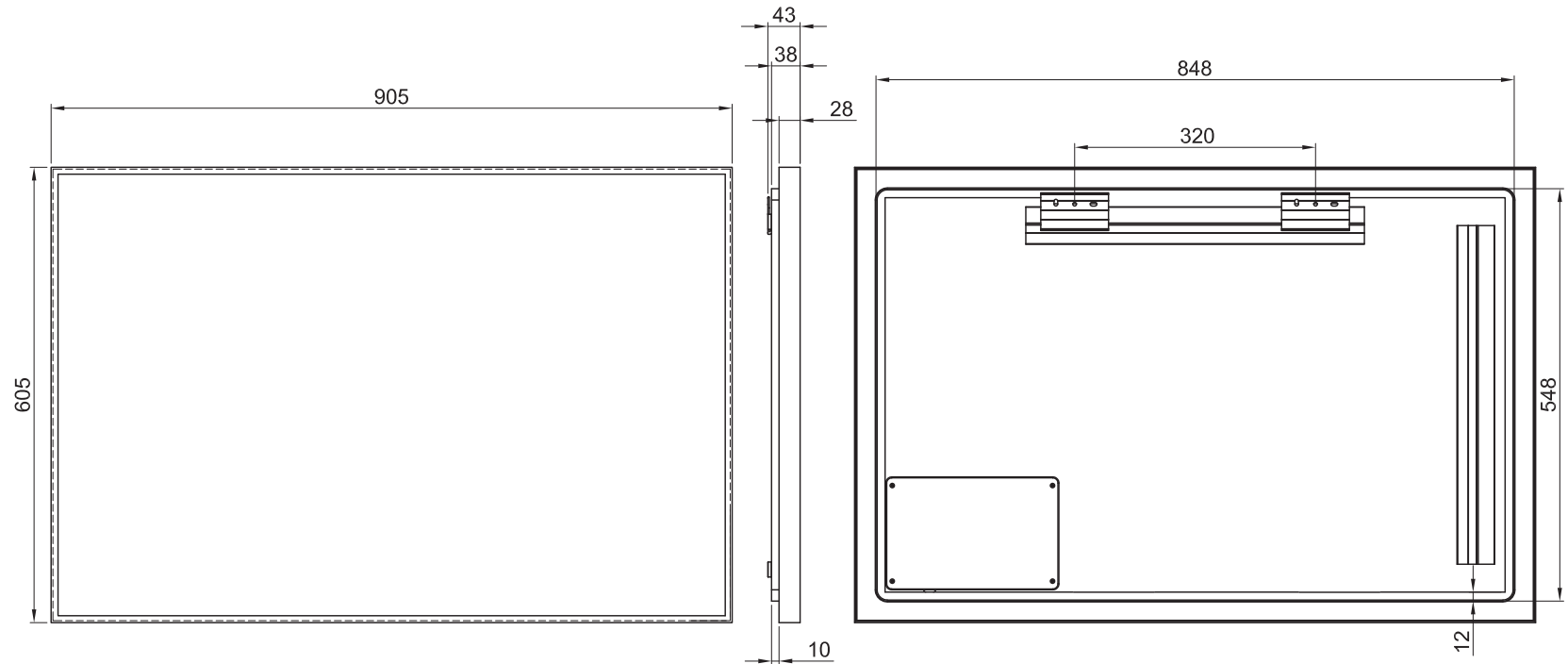

Sizes are in mm and nominal and should be checked prior to installation. Actual colours may vary so please check colour samples before ordering. Installation is acceptance of our products. Installation of faulty, warped, chipped or damaged products will void our warranty.